

ECO PHYSICS CLD 811

Application examples

- Emissions Test Benches
- Catalyst Development
- Engine Test Cells
- Car Production
- Exhaust Analysis

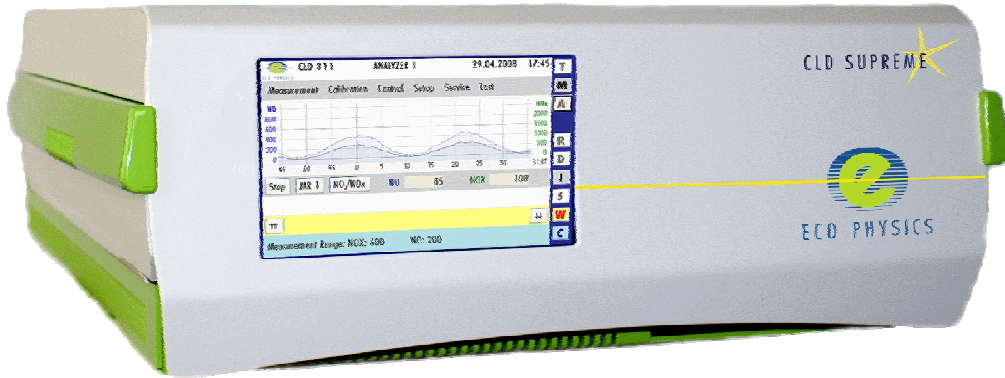

The CLD 811 nitrogen oxide analyzer is unique in its performance with a colorful touch screen display enabling easy and flexible operation. It allows the simultaneous measurement of NO, NO₂ and NO_x concentrations in raw exhaust of several thousand ppm down to a few ppb!



Monitoring of exhaust

When decimals are decisive.

The CLD 811 fulfills the requirements of the automotive industry when it comes to monitor reproducible and reliable NO_x data. With its heated inlet and its automated pressure control the analyzer can handle rough samples, such as raw exhaust gas. Beyond with the detection limit of 10 ppb bag samples may be analyzed with the same instrument.

Compact and modular design.

The CLD 811 is the most compact unit of its class. Thanks to the totally modular layout, this analyzer is designed for your system or may be placed nearby your sampling point. Thus, it will make your most indispensable measurement tool for you for a multitude of applications.

- Compact design without any additional space required
- Minimized CO₂ and H₂O quenching
- Four freely selectable measurement ranges
- Operation and control via touch screen or remote personal computer

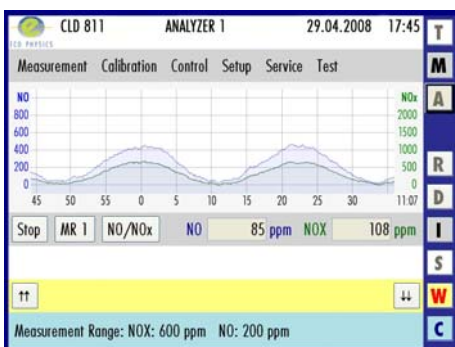

Clearly structured graphic touch screen display informs the user about real-time data and instrument status

User friendliness.

Ease of use has top priority. The analyzer powers up automatically and reaches the continuous measurement mode without any user interaction. Of course, if needed the user may choose individual sequences and select from the predefined settings in a simple menu.

Meeting tough demands.

The legislators push the environmental laws, taking giant strides. In the automotive industry the measurement of hot, raw exhaust gases is mandated by law – EURO 6 or EPA 2007 – and it is now only a question of time before this is extended to other areas, such as the manufacture of off-road engines. Therefore forward-looking suppliers of drive components verify the nitrogen oxide emissions of their products for the sake of both: the environment and quality. Only the best performing benches will lead to truly optimized engines. And many know how to achieve it: with the most reliable measuring instruments from ECO PHYSICS!

CLD 811

Specifications

Measuring ranges	four freely selectable ranges from 10-10'000 ppm	Analog output	4-20 mA into 500 Ω max. 0-1 V; 0-10 V
Min. detectable concentration	10 ppb*	Dimensions	height: 178 mm (7") width: 450 mm (19") with moulding: 495 mm depth: 620 mm(24.5")
Noise at zero point (1 σ)	5 ppb*	Weight	48 kg
Lagtime	<1 sec	Delivery includes	CLD 811 analyzer, power cable, operator's manual
Rise time (0-90%)	<1 sec	Standard	CLD 811 Heated inlet Metal converter Pressure regulation
Temperature range	5-40 °C	Options	Valve manifold
Humidity tolerance	5-95% rel. humidity (non-condensing, ambient air and sample gas)	* depending on filter setting	
Sample flow rate	1.2 l/min	ECO PHYSICS reserves the right to change these specifications without notice.	
Input pressure	750 - 1200 mbar		
Dry air use for O ₃ generator	internally generated (no external supply gas required)		
Power required	650 VA maximum (Startup) and 320 VA in operation		
Supply voltage	100-230 V/50-60 Hz		
Interface	RS 232		

Flow diagram

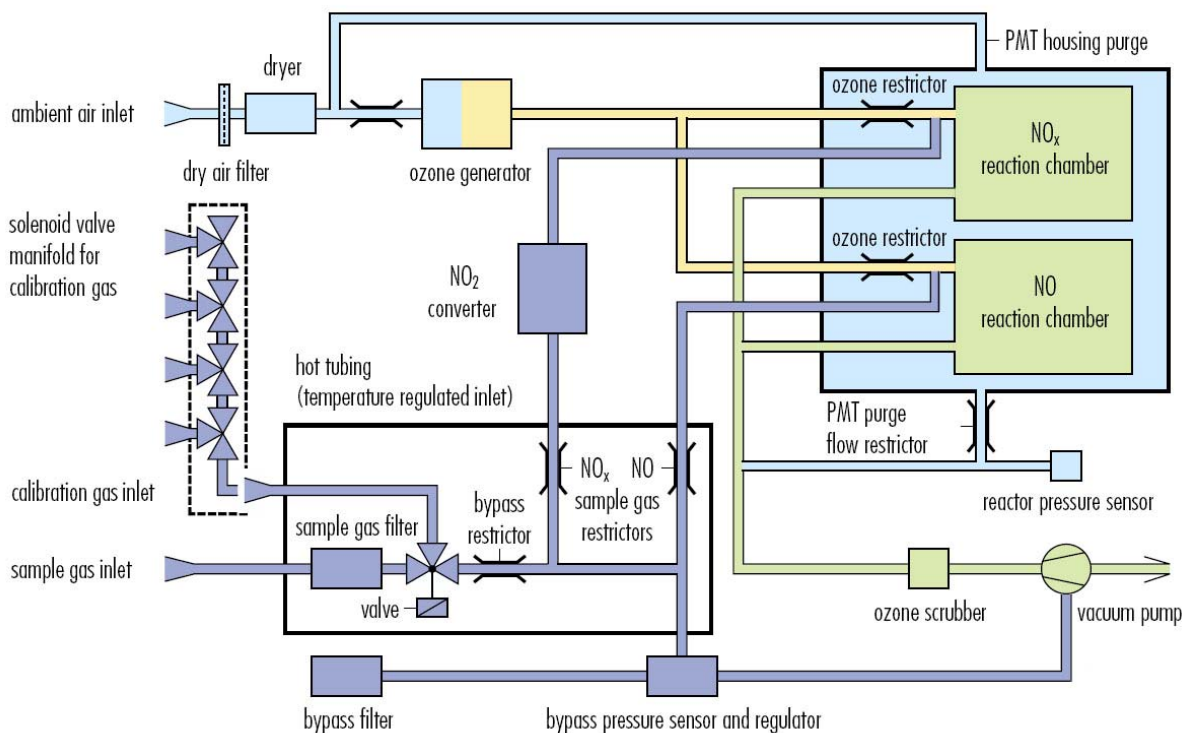

ECO PHYSICS