

ECO PHYSICS CLD 66

Application examples

- Compact design
- Internal ozone generator and scrubber
- Molybdenum or steel converter for NO_x detection
- Four freely selectable measurement ranges
- Operation and control via keypad or remote
- Mobile DC operation

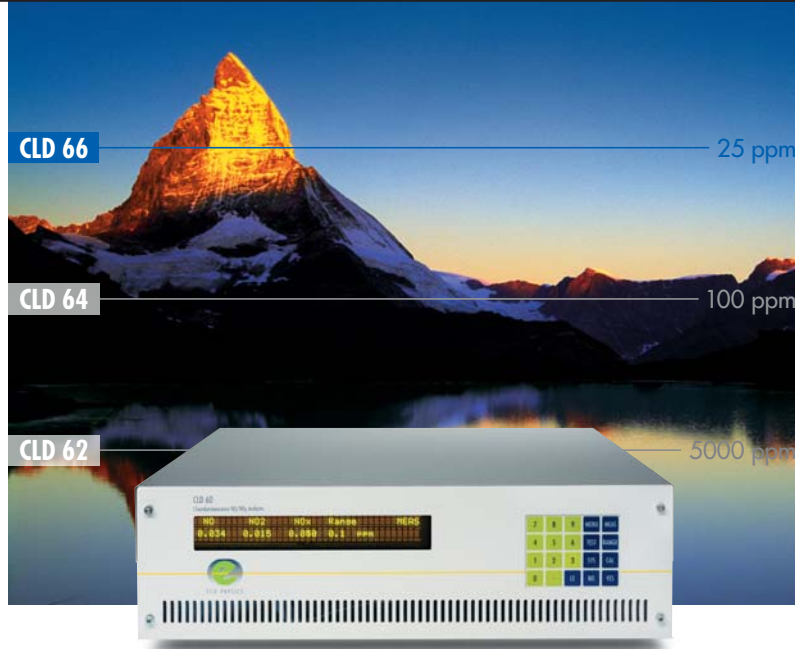

- Ambient monitoring in areas with excellent air quality
- Indoor NO₂ measurements
- Permanent monitoring of clean room conditions in R & D labs
- Biomedical and pharmaceutical research
- Plant physiological research

The new CLD 66 nitrogen oxide analyzer is the economical solution for the continuous measurement of NO, NO₂ and NO_x concentrations even in the range of parts per trillion!



Clean room laboratories require reliable and precise gas analysis.

We tell you whether the air is clean

For years ECO PHYSICS has been one of the leading firms in pollutant measurement. Our analyzers come into use wherever concentrations of nitrogen oxide compounds have to be measured. This may be for compliance with clean air regulations.

Threshold value ordinances, as well as quality directives, only make sense if they can be effectively monitored.

This is where our analyzers come into play. Either integrated into entire production processes and systems, or as stand-alone devices, they continuously deliver the exact NO, NO₂ and NO_x values you require.

Economical solution

The CLD 66 fulfills the requirements of indoor NO₂ monitoring and research laboratories specializing in detecting and monitoring smallest variations of NO/NO_x concentrations. The fast response and lag time in less than a second is unique of its class.

NO₂ and total NO_x is measured by molybdenum converter.

User-friendliness

The development of an ECO PHYSICS analyzer always includes full user comfort. The user can adapt the operation according to his needs and applications by selection of predefined settings via the keypad and remotely from a PC.

Warning and error messages are displayed coded and in full text. The analyzer guides the user step by step to return to normal operation.

Maintenance simply means annual replacement of filters and membranes besides the consumables required by special sampling conditions.

Easy calibration

Calibration is quickly and automatically carried out. This extremely useful feature eliminates the potential risk of erroneous calibrations.

Compact and modular design

The CLD 66 is the most compact unit of its class. Thanks to the totally modular layout and integrated ozone generator and scrubber it is designed for a multitude of applications.



Indoor air quality control requires NO₂ monitoring.



Parts per trillion detection for precise biomedical and pharmaceutical research.

CLD 66

Specifications

<i>Measuring ranges</i>	four freely selectable ranges from 50 to 25 000 ppb	<i>Dimensions</i>	height: 133 mm (5 ¹ / ₄ " width: 430 mm (17" depth: 455 mm (18"
<i>Min. detectable concentration</i>	0.5 ppb	<i>Weight</i>	16 kg (36 lb) without pump
<i>Noise at zero point (1σ)</i>	0.25 ppb	<i>Delivery includes</i>	CLD 66 analyzer, external power supply, power cable, vacuum pump, operator's manual
<i>Lagtime</i>	<1 sec	<i>Standard</i>	CLD 66 NO/NO _x analyzer with internal molybdenum converter
<i>Rise time (0-90%)</i>	<1 sec	<i>Options</i>	S steel converter IO analog I/O interface (dual output) L LAN DC 24 V operation incl. DC vacuum pump R rack mount slides F inlet filter
<i>Temperature range</i>	5-40 °C		
<i>Humidity tolerance</i>	5-95% rel. h (non-condensing, ambient air and sample gas)		
<i>Sample flow rate</i>	100 ml/min		
<i>Input pressure</i>	ambient		
<i>Dry air use for O₃ generator</i>	internally generated (no external supply gas required)		
<i>Power required</i>	250 VA, external membrane pump 250 VA		
<i>Supply voltage</i>	100-230 V/50-60 Hz, external power supply		
<i>Interface</i>	RS 232; LAN (optional)		
<i>Analog output (optional)</i>	4-20 mA into 500 Ω max.; 0-1 V; 0-10 V		

ECO PHYSICS reserves the right to change these specifications without notice.

Flow diagram

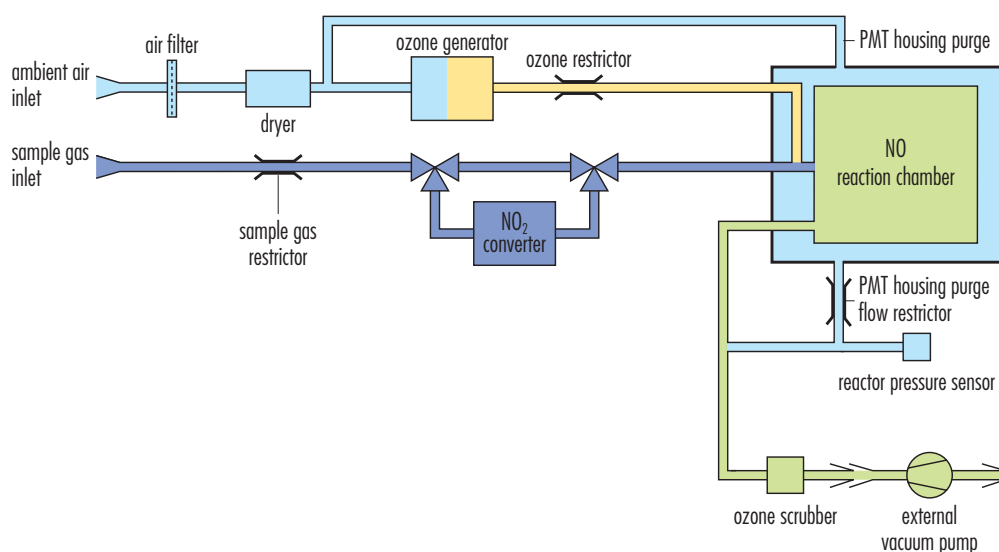

ECO PHYSICS