

CLD 700 LEV ht

Chemiluminescence Analyzers



The two-channel nitrogen oxide analyzer CLD 700 LEV ht is the new development for the measurement of exhausts in low-emission vehicles. It is designed to meet tomorrow's requirements today.

The one with the most sensitive nose.

It is in the field of engine development that the CLD 700 LEV ht really demonstrates its capabilities. These include extreme sensitivity, speed of response and linearity which are the envy of its competitors. When other analyzers can no longer measure anything, this one is still differentiating precisely between nitrogen oxide and nitrogen dioxide.

Advantages which are convincing.

Thanks to the simultaneous measurement of NO and NO_x the NO₂ values are extremely accurate. Likewise NO₂ losses due to leaching out in the sample cooler are avoided because the gases are fed directly to the instrument. The sophisticated gas flow system ensures that the measured values are accurate even in variable ambient conditions.



Packed with user-friendliness.

We make every effort to ensure that our measuring instruments simplify life for the users:

- logical user guidance
- multiline LCD
- operation and control via keypad or PC
- standardized AK protocol
- straightforward system integration
- error messages as full text and code
- virtually maintenance-free, even in continuous operation.

Application examples.

Internal combustion engine research and development
Certification of passenger vehicles
Motorcycle industry
Catalyst development and testing
Advanced fuel and combustion studies
Generators and turbines in power plants

NO_x emissions are critical for the decision: pass or fail. Developers of new driving systems with low level exhaust are looking for dependable and precise instrumentation. Even the smallest amounts of NO and NO_x just above ambient levels must be accurately detected.

The CLD 700 LEV ht sets the future standard here and now. It helps suppliers to achieve their objectives. Analyzers from ECO PHYSICS – an investment that pays off.



Trend-setting measurement techniques for pace-setting vehicle drive systems

Specifications CLD 700 LEV ht.

Measuring ranges	four user-defined ranges from 0–5 ppm to 0–500 ppm	Power required	max. 810 VA (incl. vacuum pump and ozone scrubber)
Minimal detectable concentration	0.02 ppm	Supply voltage	230 V/50 Hz, 115 V/60 Hz
Sample gas quality	dew point max. 54°C (129°F) dust and particle-free	Serial Interface	RS 232C, AK protocol, CAN
Temperature range	5–190°C (41–374°F)	Analog output	0–20 mA, 4–20 mA; load resistance 500 Ω; 0–1 V, 0.2–1 V; 0–10 V, 2–10 V
Flow rate	1.2 l/min	Dimensions	height: 133 mm; 3 HU (5¼") with feet: 158 mm (6¼")
Input pressure	600–1200 mbar abs. (8.7–17.4 psia)	Weight	width: 483 mm (19") depth: 588 mm (23⅛") 25 kg (55 lb.)
Dry air (for O₃ generator)	internally generated	Delivery includes	analyzer CLD 700 LEV ht, vacuum pump, bypass pump, ozone scrubber, RS 232C cable, analog signal cable, tubing and manual
Gases	cal. gas: NO in N ₂ zero gas: N ₂	Manufactured by ECO PHYSICS in Switzerland.	
Input pressure	2–4 bar abs. (29–58 psia)	Specifications subject to changes without notice (2005).	
Pneumatic valves	1 sample gas valve, 11 cal. gas valves, with pressure regulation		
Ambient temperature (inside rack)	5–45°C (41–113°F)		

Flow diagram CLD 700 LEV ht.

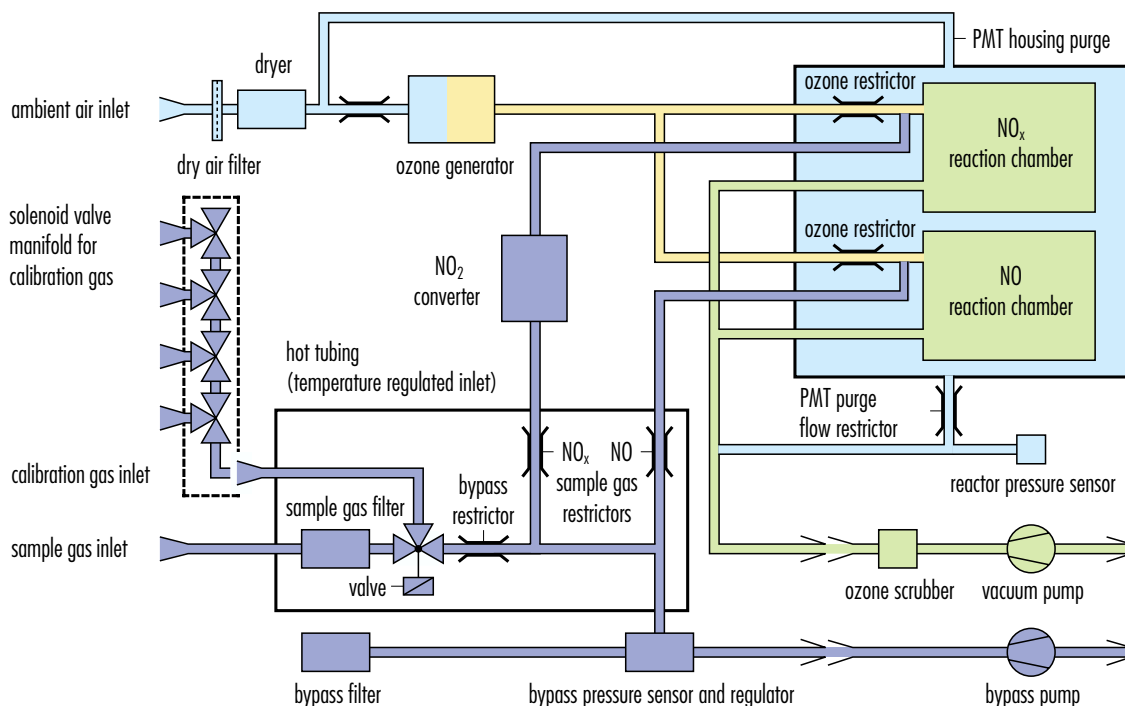

ECO PHYSICS