

ECO PHYSICS CLD 844 CM h

Application examples



- Monitoring of process chemicals and gases
- Permanent monitoring of clean room conditions
- Control of air filter systems
- Process control such as photolithography, etching, etc.
- R&D of DeNO_x devices

The CLD 844 CM h is capable to measure and display NO, NO₂, NO_x, NH₃ and the total NO_x-amines! The heated inlet minimizes chemical alterations of the sample gas.



Two instead of one.

The CLD 844 CM h analyzer is optimized for the measurement of N-containing compounds such as NO, NO₂, NH₃, NMP and amines.

The outstanding feature is the concept of two parallel reaction chambers. They guarantee simultaneous measurement of e.g. NO and NO_x in order to generate the precise value of NO₂.

Thanks to its two converter with different characteristics measuring NO_x and the total of NO_x-amines allows even to determine the NH₃. The required measurement mode can be selected via the keypad at the front panel.

A fascinating technology.

The analyzer is not only a state-of-the-art product in terms of precision and reliability. Its technological base also sets the trend for others. All components are contained in a case of only 3 HU, including vacuum pump and thermal ozone scrubber.

Naturally occurring pressure variations in the sample flow are balanced out by means of an electronic and



The CLD 844 CM h with slides is perfectly prepared for rack mounting.

mechanical bypass system (r). This module is not required in systems with an external sample pressure regulation.

Due to the heated inlet (h) no external preconditioning is required. This minimizes chemical alterations of the sample gas, e.g. salt formation with amines reduce the measured value of NH₃.

- ☐ Freely selectable measurement ranges
- ☐ Choice between several measurement modes
- ☐ Error message coded and in full text
- ☐ Rapid system integration
- ☐ Virtually maintenance-free even in continuous operation.

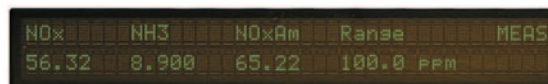

Display of NO_x-amines, and NH₃

User friendliness is a top priority.

The analyzer can be operated by means of the integrated keypad or remotely from a personal computer. The clear layout of the menu structure guides the user and enables him to take advantage of all analyzer functions with simple commands.

CLD 844 CM h

Specifications

Measuring ranges [□]	freely selectable ranges from 0.5–500 ppm	Power required [□]	400 VA (incl. membrane pump and ozone scrubber)
Min. detectable concentration [□]	0.025 ppm*	Supply voltage [□]	100–230 V/50–60 Hz
Noise at zero point (1 σ) [□]	0.012 ppm*	Interface [□]	RS 232
Lagtime [□]	<1 sec	Analog output [□]	4–20 mA into 500 Ω max.; 0–1 V; 0–10 V
Rise time (0–90%) [□]	<1 sec	Dimensions [□]	height: 133 mm (5 1/4 ") [□] width: 450 mm (19 ") [□] with moulding: 495 mm [□] depth: 545 mm
Temperature range [□]	5–40 °C	Weight [□]	26 kg
Humidity tolerance [□]	5–95% rel. h (non-condensing, ambient air and sample gas)	Delivery includes [□]	CLD 844 CM h analyzer, power cable, analog signal cable, manual
Quenching [□]	for H ₂ O: <4%/vol.-% H ₂ O [□] for CO ₂ : <1%/vol.-% CO ₂	Standard [□] CLD 844 CM h [□]	two converters for the measurement of amines and NO ₂ , heated gas inlet
Sample flow rate [□]	0.3 l/min		
Input pressure [□]	to be externally stabilized within ± 3 mbar		
Dry air use for O ₃ generator [□]	internally generated (no external supply gas required)		

* depending on filter setting

ECO PHYSICS reserves the right to change these specifications without notice.

Flow diagram

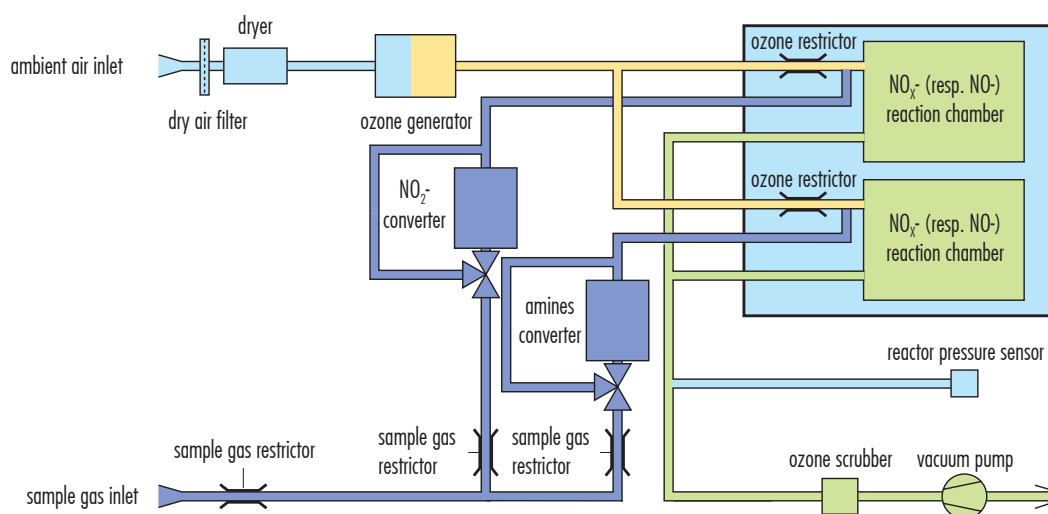

ECO PHYSICS

ECO PHYSICS AG · POB 282 · CH-8635 DUERNTEN · TEL. +41 55 220 22 22 · FAX +41 55 220 22 55 · E-MAIL INFO@ECOPHYSICS.COM
WWW.ECOPHYSICS.COM