

ECO PHYSICS CLD 84 M

Application examples



- Series checks and quality control
- Exhaust gas control
- Gas turbine installations
- Boiler and burner production
- Power plants
- Efficiency control on DeNOx installations

The CLD 84 M NO_x analyzer is the ideal instrument for series checks. It is distinguished by high precision and reliable, continuous operation.



Simply ingenious.

The CLD 84 M single channel nitrogen oxide analyzer is designed for all applications with an existing gas pre-conditioning unit to ensure quality control as well as keeping to threshold values.

The design is remarkably compact. All components, even the vacuum pump and the thermal ozone scrubber, are contained in one single unit. In spite of its simple construction the high ECO PHYSICS standard is fully complied with. The instrument includes a temperature stabilized photo multiplier and a high performance ozone generator.

Thanks to its completely modular interior the analyzer is easy to service. The reaction chamber can be removed for cleaning or replacement by following a few simple steps as shown in the picture.



Modularity means easy maintenance.

Many more applications are available as options or upgrades at a later date.



All external connections are hidden but easily accessible from the rear.

Simply user friendly.

The user can choose from four measurement ranges between 0.5 and 500 ppm. The analyzer can be operated via the keypad and remotely from a personal computer. The easy-to-read display with 2 lines of 40 characters each facilitates the gas readings and clarifies the command structure. Simple, intuitive commands are the key to full test procedures tailored to the user's needs. Even system integration can be comfortably planned and easily realized.

The analyzer operates extremely reliably and with outstanding precision.

Its design guarantees ease of use and a minimum of maintenance. The oil-free vacuum pump, for example, only needs to be checked once every 12 months.

- Four freely selectable measurement ranges up to 500 ppm NO/NO_x
- Local user guidance
- Operation and control via keypad or personal computer
- Error message coded and in full text
- Rapid system integration
- Virtually maintenance-free even in continuous operation.



CLD 84 M

Specifications

Measuring ranges	four freely selectable ranges from 0.5–500 ppm	Supply voltage	100 - 230 V/50–60 Hz
Min. detectable concentration	0.025 ppm*	Interface	RS 232 (standard)
Noise at zero point (1 σ)	0.0125 ppm*	Analog output	4–20 mA into 500 Ω max.; 0–1 V; 0–10 V
Lagtime	< 1 sec	Dimensions	height: 133 mm (5 1/4 ") width: 450 mm (19 ") with moulding: 495 mm depth: 545 mm
Rise time (0–90%)	< 1 sec	Weight	21 kg
Temperature range	5–40 °C	Delivery includes	CLD 84 M analyzer, power cable, analog signal cable, manual
Humidity tolerance	5–95% rel. h (non-condensing, ambient air and sample gas)	Standard	CLD 84 M metal converter
Quenching (with gas cooler)	for H ₂ O: <4% of meas. value for CO ₂ : <1%/vol.-% CO ₂	Options	S steel converter r electro-mechanical pressure regulation or h hot tubing
Sample flow rate	0.3 l/min (1.2 l/min with option r)		
Input pressure	externally stabilized within ± 3 mbar (600–1200 mbar abs. with option r)		
Dry air use for O₃ generator	internally generated (no external supply gas required)		
Power required	400 VA (incl. membrane pump and ozone scrubber)		

* depending on filter setting

ECO PHYSICS reserves the right to change these specifications without notice.

Flow diagram

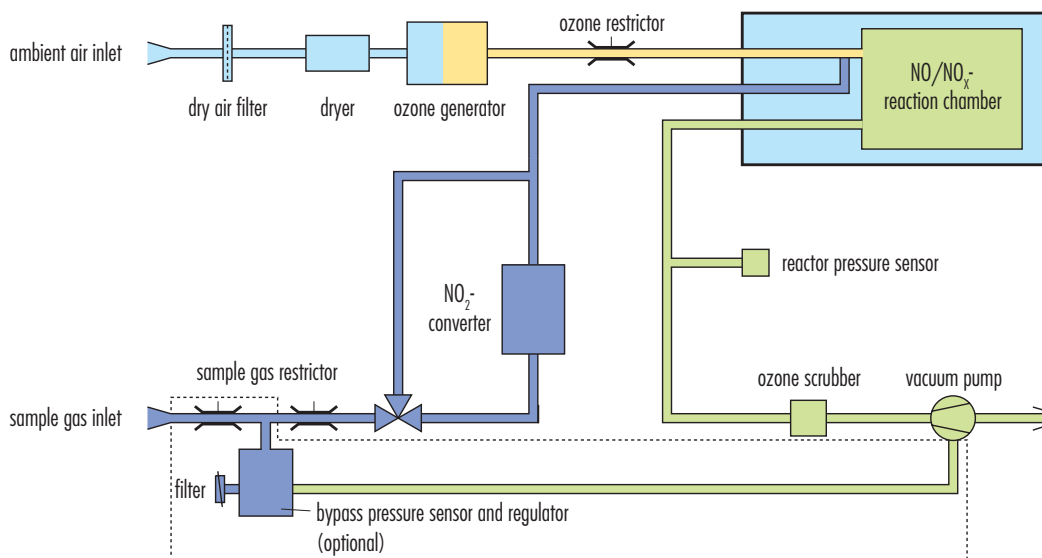

ECO PHYSICS

ECO PHYSICS AG · POB 282 · CH-8635 DUERNEN · TEL. +41 55 220 22 22 · FAX +41 55 220 22 55 · E-MAIL INFO@ECOPHYSICS.COM
WWW.ECOPHYSICS.COM