

ECO PHYSICS CLD 88 p

Application examples



Ambient monitoring in areas with excellent air quality

Supervision of production processes in the chemical and hi-tech industries

Permanent monitoring of clean room conditions in R & D labs

Biomedical and pharmaceutical research

Plant physiological research

The CLD 88 p nitrogen oxide analyzer is unique in its precision. It allows with the PLC 860 the sequential measurement of NO and NO₂ concentrations even in the range of parts per trillion!



Monitoring of ambient air quality.

When decimals are decisive.

The CLD 88 p fulfills the requirements of many research groups specializing in detecting and monitoring smallest variations of NO₂ concentrations in less than thirty seconds despite its total sample flow. The lagtime of less than a second makes it even more attractive.

NO₂ measurement is accomplished by a sequential detection of NO and NO_x. The pre-chamber minimizes zero

drift and cross sensitivity. This makes it ideally suited for areas with excellent air quality.

For specific measurements the photolytic converter unit PLC 860 can be replaced by the op-

The use of first-rate components guarantees virtually service-free operation. Maintenance simply means annual replacement of filters and membranes besides the consumables required by special sampling conditions.

Unique calibration by pressing a button!

The accuracy of chemiluminescence detection is strongly dependent on the calibration of the analyzer.

In order to assure reliability of its results the CLD 88 p analyzer has optionally a calibration module (I) for the zero level and the NO reference gas.

Calibration is quickly and automatically carried out by pressing a button on the keypad. This extremely useful feature eliminates the potential risk of erroneous calibrations.

- Compact design without any additional space required

- Photolytic converter for NO₂ detection

- Pre-chamber to offset cross sensitivity

- Four freely selectable measurement ranges

- Operation and control via keypad or personal computer

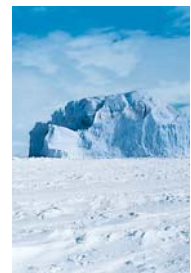

```
NO Range SNGL
39.32 100.0 PPB
```

```
Meas.Mode Recorder Autocal MENU
Date/Time Comm. Timers Filter
```

```
Time for Calibration: 50 [e] MENU
NO-Cylinder Conc.: 100.0 [PPB]
```

```
Stand-by [Y/MEAS] ?
Zero Pressure out of Range W-02
```

Clearly structured and full text displays inform the user about the instrument's status, any errors and measures to return to normal operation.

tionally available Y converter .

User friendliness.

The development of an ECO PHYSICS analyzer always requires full user comfort. The user can adapt the operation according to his needs by selection of predefined settings.

Compact and modular construction.

The CLD 88 p is the most compact unit of its class. Thanks to the totally modular layout and the rich variety of options this analyzer is designed for a multitude of applications.

CLD 88 p

Specifications

Measuring ranges	four freely selectable ranges from 5–5000 ppb	Analog output	4–20 mA into 500 Ω max.; 0–1 V; 0–10 V
Min. detectable concentration	0.05 ppb*	Dimensions	height: 133 mm (5¼ ") width: 450 mm (19 ") with moulding: 495 mm depth: 545 mm
Noise at zero point (1 σ)	0.025 ppb*	Weight	24 kg
Lagtime	<1 sec	Delivery includes	CLD 88 p analyzer, power cable, analog signal cable, manual
Rise time (0–90%)	<30 sec	Standard	CLD 88 Y p pre-chamber PLC 860 photolytic converter
Temperature range	5–40 °C		
Humidity tolerance	5–95% rel. h (non-condensing, ambient air and sample gas)		
Sample flow rate	0.3 l/min		
Input pressure	ambient		
Dry air use for O ₃ generator	internally generated (no external supply gas required)		
Power required	400 VA (incl. membrane pump and ozone scrubber)		
Supply voltage	100–230 V/50–60 Hz		
Interface	RS 232		

* depending on filter setting

ECO PHYSICS reserves the right to change these specifications without notice.

Flow diagram

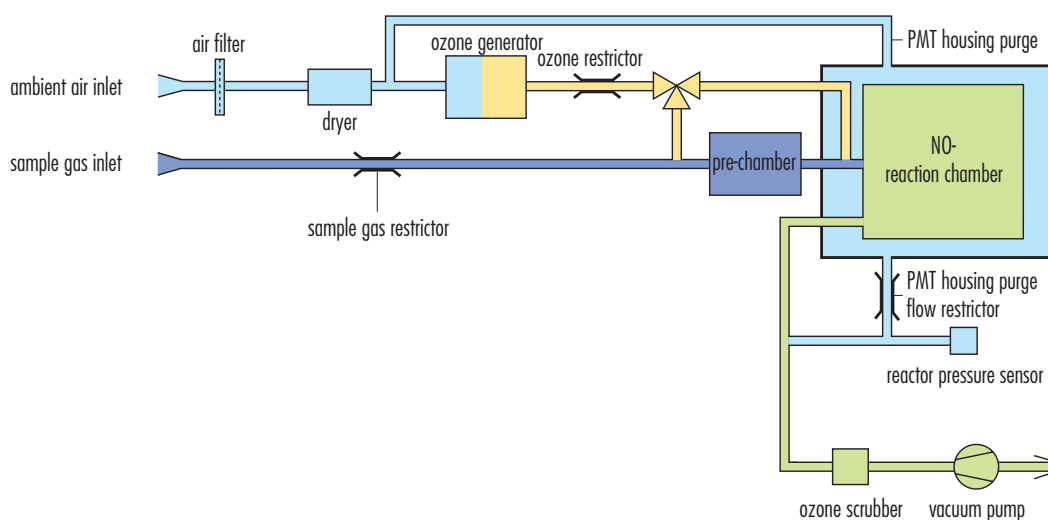

ECO PHYSICS

ECO PHYSICS AG · POB 282 · CH-8635 DUERNTEN · TEL. +41 55 220 22 22 · FAX +41 55 220 22 55 · E-MAIL INFO@ECOPHYSICS.COM
WWW.ECOPHYSICS.COM