

INFRARED GAS ANALYZER

DATA SHEET

ZRJ

This gas analyzer (ZRJ) is capable of measuring the concentrations of CO₂, CO, CH₄, SO₂, NO and O₂ components in sample gas.

CO₂, CO, CH₄, NO, and SO₂ are measured by non-dispersion infrared method (NDIR), while O₂ is measured by paramagnetic, fuel cell, or zirconia method. Up to 4 components including O₂ (up to 3 components in measurement of gases other than O₂) can be measured simultaneously.

A high-sensitivity mass flow sensor is adopted in the detection block for the infrared method. Due to use of single beam system for measurement, maintenance is easy and an excellent stability is ensured for a long period of time. In addition, a microprocessor is built in and a large-size liquid crystal display is equipped for easier operation, higher accuracy and more functions.

This analyzer is thus optimum for combustion control of various industrial furnaces, botanical study and global atmospheric research.



FEATURES

1. Simultaneous measurement of 4 components including O₂
 A maximum of 4 components are simultaneously measurable; O₂ and three components selected from among CO₂, CO, CH₄, SO₂ and NO.
 Measured values can be indicated through signal input from an externally installed O₂ analyzer.
2. Excellent in long-term stability
 The original optics (measurement block) minimizes drift particularly due to contamination of a measuring cell, so an excellent stability is ensured for a long period of time.
3. Subdued interference from other gas components
 Interference from other gas components is insignificant, because the detector is a serial dual-layer type transmission detector.
4. Easy maintenance
 Because of single-beam system the measurement block is simple with no need for optical balance adjustment. Therefore, maintenance is easy.
5. Easy to operate
 Operation can be carried out smoothly in an interactive way through a large-size liquid crystal display.
6. Abundant functions
 - Zero point and span can be accurately calibrated just by pressing the calibration keys.
 Further, the analyzer is settable so as to carry out automatic calibration periodically.
 - An error will be detected by self-diagnostic function and indicated by error message.
 - Besides, a rich variety of functions are provided including remote range input, range discrimination signal output, output signal holding and upper/lower limit alarm.

SPECIFICATIONS

Standard Specifications

Principle of measurement:

CO₂, CO, CH₄, SO₂, NO;

Non-dispersion infrared-ray absorption method

Single light source and single beam (single beam system)

O₂ ; Paramagnetic type (built in), fuel cell type (built in) or zirconia sensor method (O₂ sensor externally installed)

Measurable gas components and measuring range:

	Minimum range	Maximum range
CO ₂	0 – 500ppm	0 – 100vol%
CO	0 – 200ppm	0 – 100vol%
CH ₄	0 – 1000ppm	0 – 100vol%
SO ₂	0 – 500ppm	0 – 5000ppm
NO	0 – 500ppm	0 – 5000ppm
O ₂ (Built-in paramagnet)	0 – 5vol%	0 – 100vol%
O ₂ (External Zirconia)	0 – 5vol%	0 – 25vol%
O ₂ (Built-in galvanic cell)	0 – 10vol%	0 – 25vol%

- Max. 4 components measurement including O₂.
- 1 or 2 measuring range per component.
- Measuring range ratio ≤ 1:5 (except built in O₂)
 ≤ 1:20 (Built-in paramagnetic O₂ analyzer)

For measurable components and possible combinations of measuring ranges, refer to Tables 1 to 9.

Measured value indication:

- Digital indication in 4 digits (LCD with CFL back light)
- Instantaneous value of each component
- Instantaneous value after O₂ correction (only in CO, NO, SO₂ measurement with O₂)
- Average value after O₂ correction (only in CO, NO, SO₂ measurement with O₂)
- O₂ average value

Analog output signals:

4 to 20mA DC or 0 to 1V DC, non-isolated output.
 Analog output corresponds to measured value indication in 1:1.
 Max. load ; 550Ω for 4 to 20 mA
 Min. load ; DC100kΩ for 0 to 1V DC
 * Refer to Table 10, for the channel No. of displayed values and analog output signals.

Analog input signal:

For signal input from externally installed O₂ sensor.
 Signal requirement;
 (1) Signal from Fuji's Zirconia O₂ sensor (TYPE: ZFK7)
 (2) 0 to 1V DC from an O₂ sensor
 Input section is not isolated. This feature is effective when an O₂ sensor is not built in.
 * Externally installed O₂ sensor should be purchased separately.

Relay contact output:

1a contact (250V AC/2A, resistive load)
 Instrument error, calibration error, range discrimination, auto calibration status, solenoid valve drive for auto calibration, pump ON/OFF.
 1c contact (250V AC/2A, resistive load)
 Upper/lower alarm contact output.
 Peak count alarm contact output.
 * All relay contacts are isolated mutually and from the internal circuit.

Contact input:

Non-voltage contact (ON/0V, OFF/5V DC, 5mA flowing at ON)
 Remote range changeover, auto calibration remote start, remote holding, average value resetting
 Isolated from the internal circuit with a photocoupler. Contact inputs are not isolated from one another.

*Only M3.5 screw terminals are used for all signal inputs and outputs.

Power supply:

Voltage rating ; 100V to 240V AC
 Allowable range; 85V to 264V AC
 Frequency ; 50Hz/60Hz
 Power consumption; 70VA max.
 Inlet ; Conform to EN60320 Protection Class I

Operating conditions:

Ambient temperature; -5°C to 45°C
 Ambient humidity ; 90% RH max., non-condensing

Storage conditions:

Ambient temperature; -20°C to 60°C
 Ambient humidity ; 100% RH max., non-condensing

Dimensions (H x W x D):

19-inch rack mounting type; 177 x 483 x 493mm
 Desk-top type; 194 x 483 x 493mm

Mass:

Approx. 10 kg

Finish color:

Front panel; Off-white (Munsell 10Y7.5/0.5 or equivalent)
 Casing; Steel-blue

Enclosure:

Steel casing, for indoor use

Material of gas-contacting parts:

Gas inlet/outlet; SUS304
 Sample cell; SUS304/neoprene rubber
 Infrared-ray transmitting window; CaF₂
 Internal tubing; Toaron tube

Gas inlet/outlet:

Rc¹/₄ or NPT¹/₄ internal thread

Purge gas flow rate:

1L/min (when required)

Life time of fuel cell O₂ sensor:

2 years

Standard Functions

Output signal holding:

Output signals are held during manual and auto calibrations by activation of holding (turning on its setting).
 The values to be held are the ones just before start calibration mode.
 Indication values will not be held.

Remote output holding:

Output signal is held at the latest value by short-circuiting the remote output holding input terminals.
 Holding is maintained while the terminals are short-circuited. Indication values will not be held.

Remote range changeover:

Measuring range can be changed according to an external signal when remote range changeover input is received.
 Changeover is effective only when remote range setting is turned on. In this case, measuring range cannot be changed manually.
 When the contact input terminals for each component are short-circuited, the first range is selected, and it is changed over to the second range when the terminals are open.

Range identification signal:

The present measuring range is identified by a contact signal.
 The contact output terminals for each component are short-circuited when the first range is selected, and when the second range is selected, the terminals are open.

Auto calibration:

Auto calibration is carried out periodically at the preset cycle.
 When a standard gas cylinder for calibration and a solenoid valve for opening/closing the gas flow line are prepared externally by the customer, calibration will be carried out with the solenoid valve drive contacts for zero calibration and each span calibration turned on/off sequentially at the set auto calibration timing.

Auto calibration cycle setting:

Auto calibration cycle is set.
Setting is variable within 1 to 99 hours (in increments of 1 hour) or 1 to 40 days (in increments of 1 day).

Gas flow time setting:

The time for flowing each calibration gas in auto calibration is set.
Settable within 60 to 599 seconds (in increments of 1 second)

Auto calibration remote start:

Auto calibration is carried out only once according to an external input signal. Calibration sequence is settable in the same way as the cyclic auto calibration.
Calibration starts by opening the auto calibration remote start input terminals after short-circuiting for 1.5 seconds or longer. Auto calibration is started when the contacts open.

Auto zero calibration:

Auto zero calibration is carried out periodically at the preset cycle.
This cycle is independent on "Auto calibration" cycle.
When zero calibration gas and solenoid valve for opening/closing the calibration gas flow line are prepared externally by the customer, zero calibration will be carried out with the solenoid valve drive contact for zero calibration turned on/off at the set auto zero calibration timing.

Auto zero calibration cycle setting:

Auto zero calibration cycle is set.
Setting is variable within 1 to 99 hours (in increments of 1 hour) or setting is variable within 1 to 40 days (in increments of 1 day).

Gas flow time setting:

The timing for flowing zero gas in auto zero calibration is set.
Settable 60 to 599 seconds (in increments of 1 second)

Upper/lower limit alarm:

Alarm contact output turns on when the preset upper or lower limit alarm value is reached.
Contacts close when the instantaneous value of each component becomes larger than the upper alarm limit value or smaller than the lower alarm limit value.

Instrument error contact output:

Contacts close at occurrence of analyzer error No. 1, 3 or 10.

Calibration error contact output:

Contacts close at occurrence of manual or auto calibration error (any of errors No. 4 to 9).

Auto calibration status contact outputs:

Contacts close during auto calibration.

Pump ON/OFF contact output:

During measurement, this contact close. While calibration gas is flowing, this contact open. This contact is connected in power supply of pump, and stop the sample gas while calibration gas flowing.

Optional Functions

O₂ correction: Conversion of measured CO and SO₂ gas concentrations into values at standard O₂ concentration

$$\text{Correction formula: } C = \frac{21 - O_n}{21 - O_s} \times C_s$$

C : Sample gas concentration after O₂ correction

C_s : Measured concentration of sample gas

O_s : Measured O₂ concentration

O_n : Standard O₂ concentration (value changeable by setting)

*The upper limit value of the fractional part in this calculation is 4.

The result of calculation is indicated and output in an analog output signal.

Average value after O₂ correction and O₂ average value calculation:

The result of O₂ correction or instantaneous O₂ value can be output as an average value in the determined period of time.

Used for averaging is the moving average method in which sampling is carried out at intervals of 30 seconds.

(Output is updated every 30 seconds. It is the average value in the determined period of time just before the latest updating.)

Averaging time is settable within 1 to 59 minutes (in increments of 1 minute) or 1 to 4 hours (in increments of 1 hour).

Average value resetting:

The above-mentioned output of average value is started from the initial state by opening the average value resetting input terminals after short-circuiting for 1.5 seconds or longer.

Output is reset by short-circuiting and restarted by opening.

CO concentration peak count alarm:
(added only for CO/O₂ measurement)

Alarm output turns on according to the preset concentration and count.

Whenever the instantaneous value of CO exceeds the preset concentration value, count increments. If the count exceeds the preset value in one hour, the alarm contacts close.

Communication function:

RS-232C (9pins D-sub)

Half-duplex bit serial

Start-stop synchronization

Modbus™ protocol

Contents: Read/Wright parameters

Read measurement concentration and instrument status

Remark: When connecting via RS-485 interface, a RS-232C ↔ RS-485 converter should be used.

Performance

Repeatability : ±0.5% of full scale
Linearity : ±1% of full scale
Zero drift : ±2% of full scale/week
Span drift : ±2% of full scale/week
Response time :
(for 90% FS response)
 1 or 2 component measurement;
 Within 15 seconds including replacement
 time of sample gas
 More than 3 components measurement;
 Within 30 seconds including replacement
 time of sample gas

Interference from other gases:

Interference component	CO ₂ analyzer	CO analyzer	CH ₄ analyzer	SO ₂ analyzer	NO analyzer	Built-in paramagnetic O ₂ analyzer
CO 1000ppm	≤ 1%FS	—	≤ 1%FS	≤ 0.5%FS	≤ 1%FS	—
CO ₂ 15%	—	≤ 1%FS (for 200ppm analyzer, ≤ 2.5%FS)	≤ 1%FS	≤ 1%FS	≤ 1%FS	≤ 2% FS —
H ₂ O saturation at 20°C	≤ 1%FS	≤ 1%FS (for 500ppm analyzer, ≤ 2.5%FS)	≤ 1%FS	—	—	—
H ₂ O saturation at 2°C	—	≤ 2.5%FS (for 200ppm analyzer)	—	≤ 50ppm * (≤ 2%FS with interference compensation)	≤ 60ppm * (≤ 2%FS with interference compensation)	—
CH ₄ 1000ppm	≤ 1%FS	≤ 1%FS	—	≤ 50ppm	—	—

*The H₂O interference of NO and SO₂ analyzer can be reduced by the interference compensation function.

EC Directive Compliance

The product conforms to the requirements of the Low Voltage Directive 73/23/EEC and EMC directive 89/336/EEC (as amended by Directive 92/31/EEC), both as amended by Directive 93/68/EEC.

It conforms to following standards for product safety and electromagnetic compatibility ;

EN61010-1 : 2001 Safety requirements for electrical equipment for measurement, control and laboratory use.

“Installation Category II”

“Pollution Degree 2”

EN61326-1 : 1997, A1: 1998, A2: 2001

Electrical equipment for measurement, control and laboratory use — EMC requirements.

Standard Requirements for Sample Gas

Flow rate : 1L / min ±0.5L / min
Temperature : 0 to 50°C
Pressure : 10 kPa or less (Gas outlet side should be open to the atmospheric air.)
Dust : 100 µg/Nm³ or less in particle size of 0.3 µm or less
Mist : Unallowable
Moisture : Below a level where saturation occurs at room temperature (condensation unallowable).
 Below the level where saturation occurs at 2°C for CO measurement in 0 to 200 ppm range, NO measurement, and SO₂ measurement.

Corrosive component:

1 ppm or less

Standard gas for calibration:

Zero gas ; Dry N₂

Span gas ; Each sample gas having concentration 90 to 100% of its measuring range (recommended).

Gas beyond concentration 100% is unusable.

In case a zirconia O₂ analyzer is installed externally and calibration is carried out on the same calibration gas line:

Zero gas ; Dry air or atmospheric air

Span gas ; For other than O₂ measurement, each sample gas having concentration 90 to 100% of its measuring range
 For O₂ measurement, O₂ gas of 1 to 2 vol%

Installation Requirements

- Indoor use (Select a place where the equipment does not receive direct sunlight, draft/rain or radiation from hot substances. If such a place cannot be found, a roof or cover should be prepared for protection.)
- Avoid a place where receives heavy vibration
- Select a place where atmospheric air is clean

Principle diagram of NDIR type measurement (For CO₂, CO, CH₄, SO₂, NO)

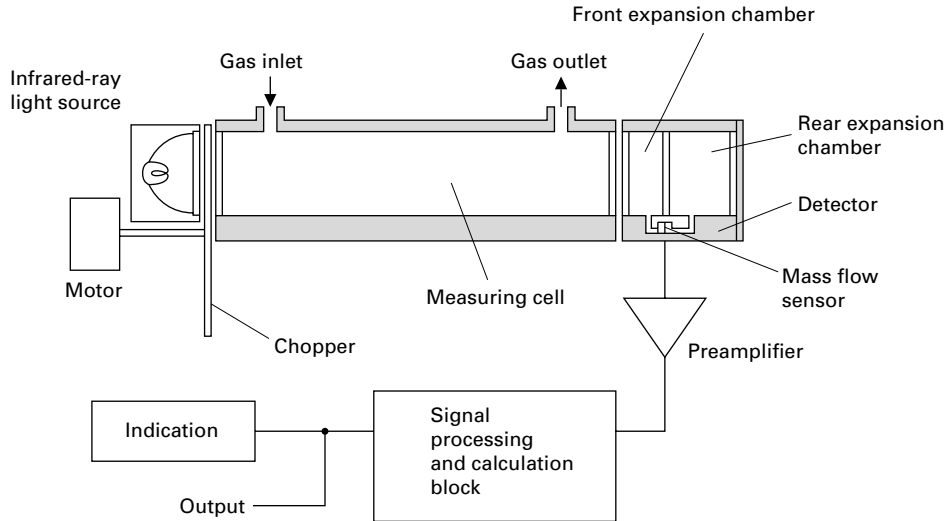

Principle diagram of paramagnetic type measurement (For O₂)

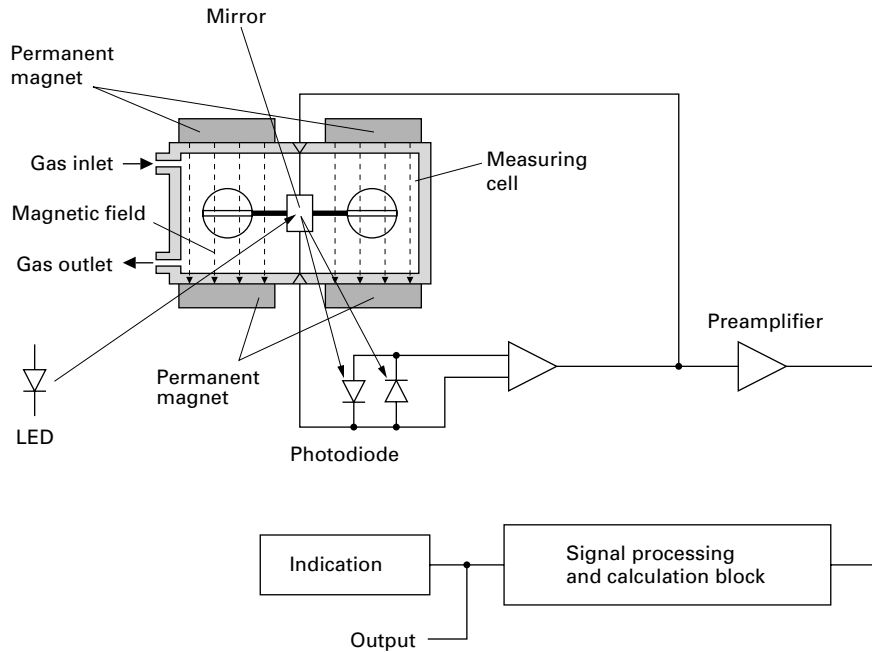

Principle diagram of fuel cell type measurement (For O₂)

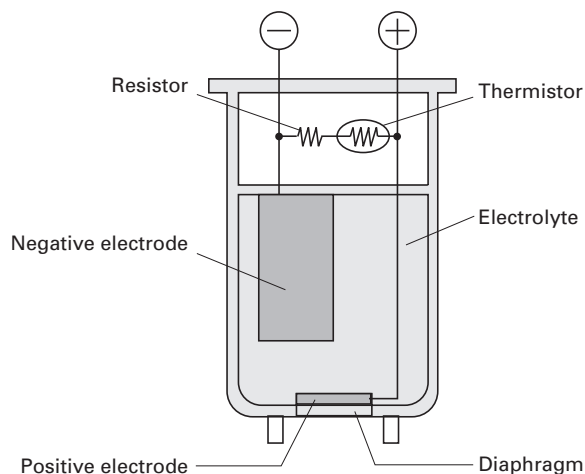

To measure low moisture content (saturated at room temperature or lower) sample gas (CO, CO₂, CH₄)

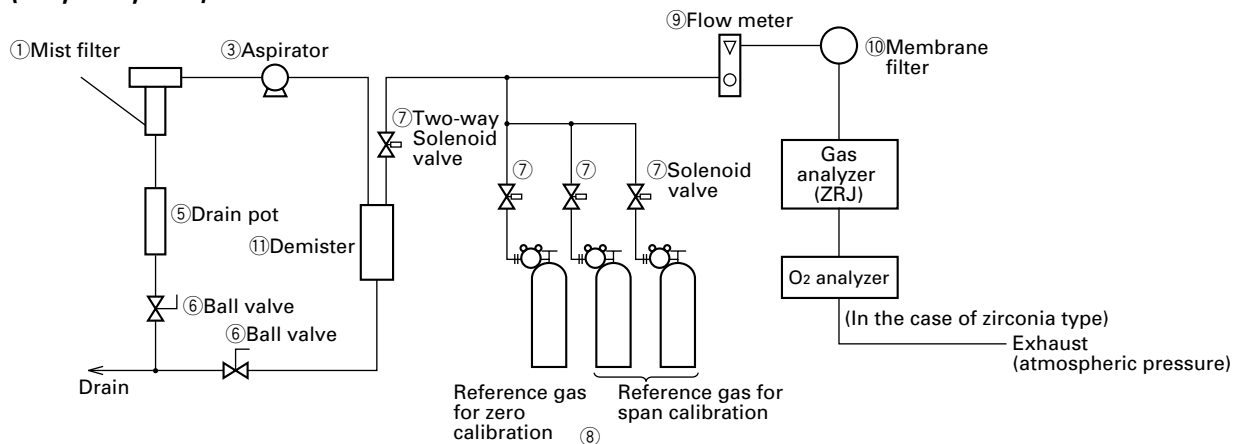

To measure high moisture content sample gas, NO, SO₂, or CO (0 to 200 ppm range)

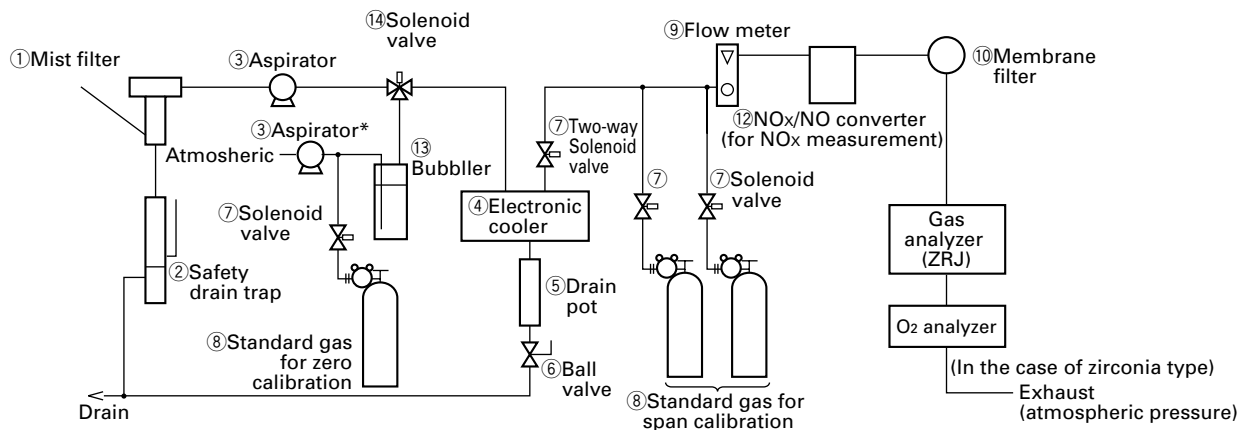

* Be sure to use a dehumidifier for NO, SO₂, and CO analyzers of 0 to 200 ppm range (≒2°C saturation or lower).
Supply zero calibration gas at atmospheric or contained in a cylinder after performing bubbling (humidifying) to decrease interference by Interference compensation

Sampling device list (example)

List of sampling devices

No.	Device name	Fuji's type
①	Mist filter	ZBKB1V03-0
②	Safety drain trap	ZBH51603
③	Aspirator	ZBG80
④	Electronic cooler	ZBC91003
⑤	Drain pot	ZBH13003 (Length 255mm)
⑥	Ball valve	ZBFB1
⑦	Two-way solenoid valve	
⑧	Standard gas for calibration	ZBM□Y04-0□ (Codes in □ to be selected depending on application)
⑨	Flow meter	ZBD42203
⑩	Membrane filter	ZBBM2V03-0
⑪	Demister	ZBH35003
⑫	NO ₂ /NO converter	ZDL02001
⑬	Bubbler	ZBH65003
⑭	Solenoid valve	

CODE SYMBOLS

Digit	Description	note	1	2	3	4	5	6	7	8	9	10	11	12	13	14	15	16	17	18	19	20	21	← Digit No. of code
4	<Custom specifications> Standard		Z	R	J																			
5	<Measurable component (SO ₂ , CO ₂ , CO, CH ₄) > None SO ₂ CO CO ₂ CH ₄ NO NO+SO ₂ NO+CO CO ₂ +CO CH ₄ +CO CO ₂ +CH ₄ CO ₂ +CO+CH ₄ NO+SO ₂ +CO Others	note 1				F																		
6	<Measurable component (O ₂)> None External zirconia type sensor (ZFK7) External O ₂ analyzer Built-in paramagnetic type O ₂ sensor Built-in fuel cell type O ₂ sensor	note 2 note 2																						
7	<Gas inlet/outlet> Rc1/4 on back face Rc1/4 on back face with purging NPT1/4 on back face NPT1/4 on back face with purging																							
8	<Revision code>									5														
9	<Structure> Table-top type 19-inch rack mounting type 19-inch rack mounting type with slide rail																							
10	<Indication and power supply cable> In Japanese, Power cable rated 125V In English, Power cable rated 125V (UL) In English, Power cable rated 250V (CEE)	note 3																						
11	<Measuring range> 1st component, 1st range None 0 to 200ppm 0 to 500ppm 0 to 1000ppm 0 to 2000ppm 0 to 2500ppm 0 to 5000ppm 0 to 1% 0 to 2% 0 to 3% 0 to 5% 0 to 10% 0 to 20% 0 to 25% 0 to 40% 0 to 50% 0 to 70% 0 to 100% Others	note 4 note 1 note 5 note 6																						
12	<Measuring range> 1st component, 2nd range None 0 to 500ppm 0 to 1000ppm 0 to 2000ppm 0 to 2500ppm 0 to 5000ppm 0 to 1% 0 to 2% 0 to 5% 0 to 10% 0 to 20% 0 to 25% 0 to 50% 0 to 100% Others	note 4																						

Digit	Description	note	1	2	3	4	5	6	7	8	9	10	11	12	13	14	15	16	17	18	19	20	21
13	<Measuring range> 2nd component, 1st range None 0 to 500ppm 0 to 1000ppm 0 to 2000ppm 0 to 2500ppm 0 to 5000ppm ----- 0 to 1% 0 to 2% 0 to 3% 0 to 5% 0 to 10% 0 to 20% 0 to 25% 0 to 40% 0 to 50% 0 to 70% 0 to 100% Others	note 4	Z	R	J											Y							
																E							
																F							
																G							
																H							
																U							
																G							
																H							
																J							
																K							
																L							
																M							
																N							
																V							
																P							
																R							
																R							
																Z							
14	<Measuring range> 2nd component, 2nd range None 0 to 1000ppm 0 to 2000ppm 0 to 2500ppm 0 to 5000ppm ----- 0 to 1% 0 to 2% 0 to 5% 0 to 10% 0 to 20% 0 to 25% 0 to 50% 0 to 100% Others	note 4														Y							
																F							
																G							
																H							
																J							
																K							
																L							
																M							
																N							
																V							
																P							
																R							
																R							
																Z							
15	<Measuring range> 3rd component, 1st range None 0 to 500ppm 0 to 1000ppm 0 to 2000ppm 0 to 2500ppm 0 to 5000ppm ----- 0 to 1% 0 to 2% 0 to 3% 0 to 5% 0 to 10% 0 to 20% 0 to 25% 0 to 40% 0 to 50% 0 to 70% 0 to 100% Others	note 4														Y							
																E							
																F							
																G							
																H							
																J							
																K							
																L							
																M							
																N							
																V							
																P							
																R							
																R							
																Z							
16	<Measuring range> 3rd component, 2nd range None 0 to 1000ppm 0 to 2000ppm 0 to 2500ppm 0 to 5000ppm ----- 0 to 1% 0 to 2% 0 to 5% 0 to 10% 0 to 20% 0 to 25% 0 to 50% 0 to 100% Others	note 4														Y							
																F							
																G							
																H							
																J							
																K							
																L							
																M							
																N							
																V							
																P							
																R							
																R							
																Z							
17	<O ₂ analyzer, 1st range> None 0 to 5% 0 to 10% 0 to 25% 0 to 50% 0 to 100% Others	note 4														Y							
																L							
																M							
																V							
																P							
																R							
																Z							

← Digit No. of code

Digit	Description	note	1	2	3	4	5	6	7	8	9	10	11	12	13	14	15	16	17	18	19	20	21						
18	<O ₂ analyzer, 2nd range> None 0 to 10% 0 to 25% 0 to 50% 0 to 100% Others	note 4	Z	R	J																Y	M	V	P	R	Z			
19	<Output> 4 to 20mA DC 0 to 1V DC 4 to 20mA DC + Communication function 0 to 1V DC + Communication function																								A	B	C	D	
20	<O ₂ correction and O ₂ average value output> None With O ₂ correction output and average output With Peak count alarm output With O ₂ correction and average output, and peak count alarm output Others	note 7 note 8																							Y	A	B	C	Z
21	Adjustment, Unit Standard, Unit ppm For heat treatment, Unit ppm Standard, Unit mg/m ³ Others	note 9																								A	B	C	Z

<Code specification for ordering>

(1) Code symbols should be specified.

(2) Range combination should be the one allowed in separate tables.

(note1) When only O₂ measurement is necessary, "Y" should be specified at the 5th digit.

In this case, specify O₂ measuring range at 17th 18th digits.

(note2) When "B" is specified at the 6th digit, O₂ sensor signal has to be set as 0-1V DC linear corresponding to full scale.

External Zirconia O₂ sensor and external O₂ analyzer are not included in the scope of supply, and has to be separately ordered..

(note3) Rated voltage and plug type of the attached power cable is different depending on the code "J", "E" and "U" in the 10th digit.

Select appropriate code according to operating power supply voltage in the final destination.

(note4) Refer to Table 1 to 9, for possible combination of measuring components and ranges in the data sheet.

(note5) "C" can be specified at 11th digits, ONLY for CO measurement.

(note6) "E" can be specified at 11th digits, except CH₄ measurement.

(note7) O₂ correction is calculated only for NO, SO₂ and CO.

Both average value output after O₂ calculation and O₂ average value output are provided at the same time.

Peak count alarm can be added only for CO measurement.

* With the triple-component analyzer for NO, SO₂, and CO, the values after correction only are displayed and output (average of corrected values is not output). If the average value should be output, specify Z, and separately describe what values should be output. Up to 8 values can be output.

Peak count alarm can be added only for CO measurement.

(note8) When no O₂ measurement, "Y" should be specified.

(note9) This analyzer has different calibration curve corresponding to sample gas composition.

When "B" or "Z" is specified at the 21th digit, the gas composition table should be issued.

"Standard" means N₂ balance adjustment.

In case that the measurement unit is specified as "mg/m³", it is necessary to select "unit : mg/m³" (Code "C") at the 21st digit.

Please refer to the table shown below for the corresponding range code based on "mg/m³".

Range code	In ppm	Corresponding range in mg/m ³		
		NO	SO ₂	CO
C	0 to 200ppm	—	—	0 to 250mg/m ³
E	0 to 500ppm	0 to 650mg/m ³	0 to 1400mg/m ³	0 to 600mg/m ³
F	0 to 1000ppm	0 to 1300mg/m ³	0 to 2800mg/m ³	0 to 1250mg/m ³
G	0 to 2000ppm	0 to 2600mg/m ³	0 to 5600mg/m ³	0 to 2500mg/m ³

The conversion formula "ppm" unit into "mg/m³" unit

$$\text{NO}(\text{mg}/\text{m}^3) = 1.34 \times \text{NO}(\text{ppm})$$

$$\text{SO}_2(\text{mg}/\text{m}^3) = 2.86 \times \text{SO}_2(\text{ppm})$$

$$\text{CO}(\text{mg}/\text{m}^3) = 1.25 \times \text{CO}(\text{ppm})$$

SCOPE OF DELIVERY

Gas analyzer ... 1 unit

Power cable (standard inlet type 2m) ... 1 pc

Replacement fuse (250V, 1A AC, delay type) ... 2 pcs

Instruction manual ... 1 copy

Slide rail ... 2 pcs (when with slide rail is selected)

ORDERING INFORMATION

1. Code symbols

2. Application and composition of sample gas

Measurable component and range - availability check table -

Table 1: Single-component analyzer (CO₂, CO, CH₄, SO₂, NO)

1st range	2nd range							
	0 to 500ppm	0 to 1000ppm	0 to 2000ppm	0 to 2500ppm	0 to 5000ppm	0 to 1%	0 to 2%	0 to 3%
0 to 200ppm	○	○	—	—	—	—	—	—
0 to 500ppm	—	◎○☆	◎○☆	◎○☆	—	—	—	—
0 to 1000ppm	—	—	◎○△□☆	◎○△□☆	◎○△□☆	—	—	—
0 to 2000ppm	—	—	—	◎○△□☆	◎○△□☆	◎○△	—	—
0 to 2500ppm	—	—	—	—	◎○△□☆	◎○△	—	—
0 to 5000ppm	—	—	—	—	—	◎○△	◎○△	—
0 to 1%	—	—	—	—	—	—	◎○△	◎○△
0 to 2%	—	—	—	—	—	—	—	◎○△
0 to 3%	—	—	—	—	—	—	—	—
0 to 5%	—	—	—	—	—	—	—	—
0 to 10%	—	—	—	—	—	—	—	—
0 to 20%	—	—	—	—	—	—	—	—
0 to 25%	—	—	—	—	—	—	—	—
0 to 40%	—	—	—	—	—	—	—	—
0 to 50%	—	—	—	—	—	—	—	—
0 to 70%	—	—	—	—	—	—	—	—
0 to 100%	—	—	—	—	—	—	—	—

1st range	2nd range							
	0 to 5%	0 to 10%	0 to 20%	0 to 25%	0 to 40%	0 to 50%	0 to 70%	0 to 100%
0 to 200ppm	—	—	—	—	—	—	—	—
0 to 500ppm	—	—	—	—	—	—	—	—
0 to 1000ppm	—	—	—	—	—	—	—	—
0 to 2000ppm	—	—	—	—	—	—	—	—
0 to 2500ppm	—	—	—	—	—	—	—	—
0 to 5000ppm	—	—	—	—	—	—	—	—
0 to 1%	◎○△	—	—	—	—	—	—	—
0 to 2%	◎○△	◎○△	—	—	—	—	—	—
0 to 3%	◎○△	◎○△	—	—	—	—	—	—
0 to 5%	—	◎○△	◎○△	◎○△	—	—	—	—
0 to 10%	—	—	◎○△	◎○△	◎○△	◎○△	—	—
0 to 20%	—	—	—	◎○△	◎○△	◎○△	◎○	◎○
0 to 25%	—	—	—	—	◎○△	◎○△	◎○	◎○
0 to 40%	—	—	—	—	—	◎○△	◎○△	◎○△
0 to 50%	—	—	—	—	—	—	◎○△	◎○△
0 to 70%	—	—	—	—	—	—	—	◎○△
0 to 100%	—	—	—	—	—	—	—	◎○△

◎: CO₂ analyzer measurable range ○: CO analyzer measurable range ☆: NO analyzer measurable range
 △: CH₄ analyzer measurable range □: SO₂ analyzer measurable range

*Note) Single range is also available.

Table 2: Double-components analyzer (CO₂ and CO)

1st component	2nd component →	CO									
		0 to 500ppm 0 to 1000ppm	0 to 1000ppm 0 to 2000ppm	0 to 2000ppm 0 to 5000ppm	0 to 5000ppm 0 to 1%	0 to 1% 0 to 2%	0 to 2% 0 to 5%	0 to 5% 0 to 10%	0 to 10% 0 to 20%	0 to 20% 0 to 50%	0 to 50% 0 to 100%
CO ₂	0 to 5000ppm 0 to 1%	—	◎	◎	◎	◎	◎	◎	◎	◎	◎
	0 to 1% 0 to 2%	◎	◎	◎	◎	◎	◎	◎	◎	◎	◎
	0 to 2% 0 to 5%	◎	◎	◎	◎	◎	◎	◎	◎	※	◎
	0 to 5% 0 to 10%	◎	◎	◎	◎	◎	◎	◎	◎	◎	◎
	0 to 10% 0 to 20%	◎	◎	◎	◎	◎	◎	◎	◎	◎	◎
	0 to 20% 0 to 50%	◎	◎	◎	◎	◎	◎	◎	◎	◎	◎
	0 to 50% 0 to 100%	—	◎	◎	◎	◎	◎	◎	◎	◎	◎

◎: Single range or double range is available (middle range between 1st and 2nd range is also available),

※: Only single range is available one component one range

Table 3: Double-components analyzer (CH₄ and CO)

	↓ 1st component	2nd component →									
		CO					CO				
	1st range 2nd range	0 to 500ppm 0 to 1000ppm	0 to 1000ppm 0 to 2000ppm	0 to 2000ppm 0 to 5000ppm	0 to 5000ppm 0 to 1%	0 to 1% 0 to 2%	0 to 2% 0 to 5%	0 to 5% 0 to 10%	0 to 10% 0 to 20%	0 to 20% 0 to 50%	0 to 50% 0 to 100%
CH ₄	0 to 5000ppm 0 to 1%	—	⊙	⊙	⊙	⊙	※	⊙	⊙	⊙	—
	0 to 1% 0 to 2%	—	⊙	⊙	⊙	⊙	※	⊙	⊙	⊙	※
	0 to 2% 0 to 5%	⊙	⊙	⊙	⊙	⊙	⊙	⊙	⊙	⊙	⊙
	0 to 5% 0 to 10%	⊙	⊙	⊙	⊙	⊙	⊙	⊙	⊙	⊙	⊙
	0 to 10% 0 to 20%	⊙	⊙	⊙	⊙	⊙	⊙	⊙	⊙	⊙	⊙
	0 to 20% 0 to 50%	—	⊙	⊙	⊙	⊙	⊙	⊙	⊙	⊙	⊙
	0 to 50% 0 to 100%	—	—	—	⊙	⊙	⊙	⊙	⊙	⊙	⊙

⊙: Single range or double range is available (middle range between 1st and 2nd range is also available),

※: Only single range is available one component one range

Table 4: Double-components analyzer (CO₂ and CH₄)

	↓ 1st component	2nd component →								
		CO ₂					CH ₄			
	1st range 2nd range	0 to 1000ppm 0 to 2000ppm	0 to 2000ppm 0 to 5000ppm	0 to 5000ppm 0 to 1%	0 to 1% 0 to 2%	0 to 2% 0 to 5%	0 to 5% 0 to 10%	0 to 10% 0 to 20%	0 to 20% 0 to 50%	0 to 50% 0 to 100%
CO ₂	0 to 2000ppm 0 to 5000ppm	—	—	⊙	⊙	⊙	⊙	⊙	—	—
	0 to 5000ppm 0 to 1%	—	—	⊙	⊙	⊙	⊙	⊙	⊙	—
	0 to 1% 0 to 2%	⊙	⊙	⊙	⊙	⊙	⊙	⊙	⊙	—
	0 to 2% 0 to 5%	⊙	⊙	⊙	⊙	⊙	⊙	⊙	⊙	⊙
	0 to 5% 0 to 10%	⊙	⊙	⊙	⊙	⊙	⊙	⊙	⊙	⊙
	0 to 10% 0 to 20%	⊙	⊙	⊙	⊙	⊙	⊙	⊙	⊙	⊙
	0 to 20% 0 to 50%	⊙	⊙	⊙	⊙	⊙	⊙	⊙	⊙	⊙
	0 to 50% 0 to 100%	—	⊙	⊙	⊙	⊙	⊙	⊙	⊙	⊙

⊙: Single range or double range is available (middle range between 1st and 2nd range is also available)

Table 5: Double-components analyzer (NO and SO₂)

	↓ 1st component	2nd component → SO ₂	
		0 to 500ppm 0 to 2000ppm	0 to 1000ppm 0 to 5000ppm
NO	0 to 500ppm 0 to 2000ppm	⊙	⊙
	0 to 1000ppm 0 to 5000ppm	⊙	⊙

⊙: Single range or double range is available (middle range between 1st and 2nd range is also available)

Table 6: Double-components analyzer (NO and CO)

	↓ 1st component	2nd component →			
		CO			
	1st range 2nd range	0 to 200ppm 0 to 1000ppm	0 to 500ppm 0 to 2000ppm	0 to 1000ppm 0 to 5000ppm	0 to 2000ppm 0 to 1%
NO	0 to 500ppm 0 to 5000ppm	⊙	⊙	⊙	⊙
	0 to 1000ppm 0 to 5000ppm	⊙	⊙	⊙	⊙

⊙: Single range or double range is available (middle range between 1st and 2nd range is also available)

Table 7: Triple-component analyzer (CO₂, CO and CH₄)..... Covered table 2, table 3 and table 4.

Table 8: Triple-component analyzer (NO/SO₂/CO)..... NO/SO₂ by Table 5 and CO by Table 1 (maximum CO range: 0 to 1%)

Table 9: O₂ analyzer

2nd range 1st range		M	V	P	R
		0 to 10%	0 to 25%	0 to 50%	0 to 100%
L	0 to 5%	○△	○△	○	—
M	0 to 10%	—	○△□	○	○
V	0 to 25%	—	—	○	○
P	0 to 50%	—	—	—	○
R	0 to 100%	—	—	—	○

○: Built-in paramagnetic type O₂ analyzer measurable range,

△: External zirconia type O₂ analyzer measurable range

□: Built-in fuel cell type O₂ analyzer measurable range

*O₂ analyzer is selectable indifferently to combination with other components.

External zirconia type O₂ analyzer is assumed to be Fuji's type ZFK7.

Table 10: Channel(CH) No. and display/output contents comparison table

Code symbol			Display/output contents corresponding to each channel (CH) No.							
5th digit	6th digit	20th digit	CH1	CH2	CH3	CH4	CH5	CH6	CH7	CH8
Y	C	Y	O ₂							
P	Y	Y	NO							
A	Y	Y	SO ₂							
D	Y	Y	CO ₂							
B	Y	Y	CO							
E	Y	Y	CH ₄							
F	Y	Y	NO	SO ₂						
H	Y	Y	NO	CO						
2	Y	Y	CO ₂	CO						
3	Y	Y	CH ₄	CO						
4	Y	Y	CO ₂	CH ₄						
L	Y	Y	NO	SO ₂	CO					
5	Y	Y	CO ₂	CO	CH ₄					
P	A, B, C, D	Y	NO	O ₂						
A	A, B, C, D	Y	SO ₂	O ₂						
D	A, B, C, D	Y	CO ₂	O ₂						
B	A, B, C, D	Y, B	CO	O ₂						
E	A, B, C, D	Y	CH ₄	O ₂						
F	A, B, C, D	Y	NO	SO ₂	O ₂					
H	A, B, C, D	Y, B	NO	CO	O ₂					
2	A, B, C, D	Y, B	CO ₂	CO	O ₂					
3	A, B, C, D	Y, B	CH ₄	CO	O ₂					
4	A, B, C, D	Y	CO ₂	CH ₄	O ₂					
L	A, B, C, D	Y, B	NO	SO ₂	CO	O ₂				
5	A, B, C, D	Y, B	CO ₂	CO	CH ₄	O ₂				
P	A, B, C, D	A	NO _x	O ₂	Correct NO _x	Correct NO _x average	O ₂ average			
A	A, B, C, D	A	SO ₂	O ₂	Correct SO ₂	Correct SO ₂ average	O ₂ average			
B	A, B, C, D	A, C	CO	O ₂	Correct CO	Correct CO average	O ₂ average			
F	A, B, C, D	A	NO _x	SO ₂	O ₂	Correct NO _x	Correct SO ₂	Correct NO _x average	Correct SO ₂ average	O ₂ average
H	A, B, C, D	A, C	NO _x	CO	O ₂	Correct NO _x	Correct CO	Correct NO _x average	Correct CO average	O ₂ average
2	A, B, C, D	A, C	CO ₂	CO	O ₂	Correct CO	Correct CO average	O ₂ average		
3	A, B, C, D	A, C	CH ₄	CO	O ₂	Correct CO	Correct CO average	O ₂ average		
L	A, B, C, D	A, C	NO _x	SO ₂	CO	O ₂	Correct NO _x	Correct SO ₂	Correct CO	O ₂ average
5	A, B, C, D	A, C	CO ₂	CO ₂	CH ₄	O ₂	Correct CO	Correct CO average	O ₂ average	

* Study of table

When CH1 shows SO₂, it means that the display and the output of CH1 correspond to the component of SO₂.

The "correct" means O₂ correction.

If A or C is selected for the 20th digit of the code symbols, "NO_x" is displayed as the component display of "NO."

OUTLINE DIAGRAM (Unit : mm)

<UPPER>

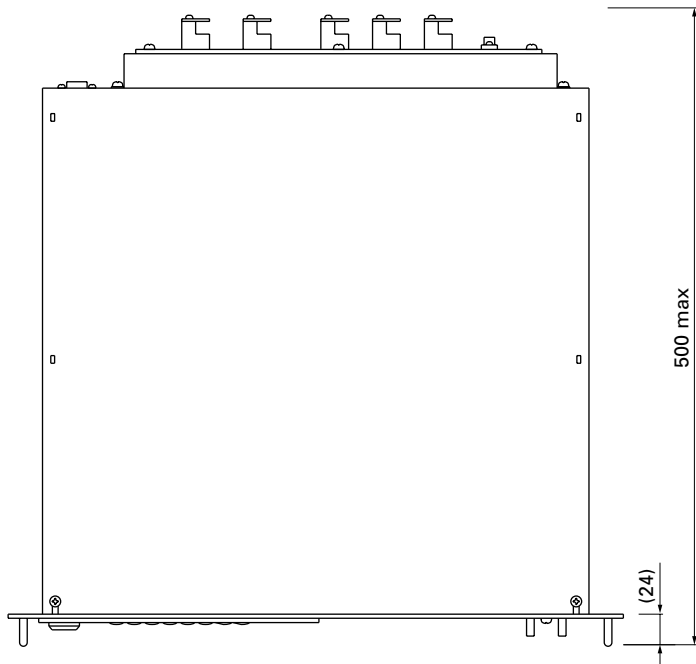

<SIDE>

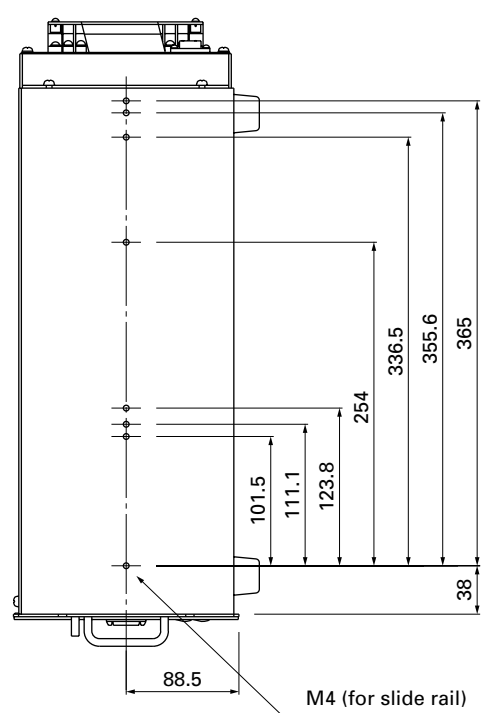

Power Switch

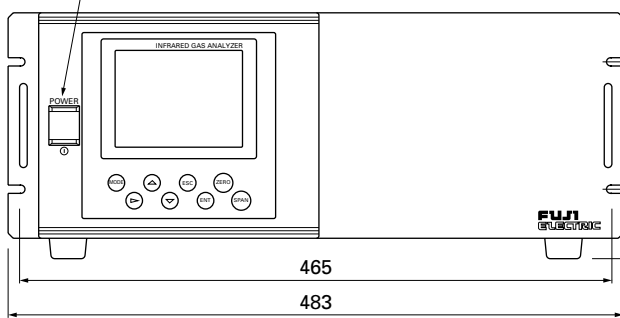

<Rack mount hole pitch>

M5

<FRONT>

Applicable both for
JIS 100 mm and
EiA 101.6 mm

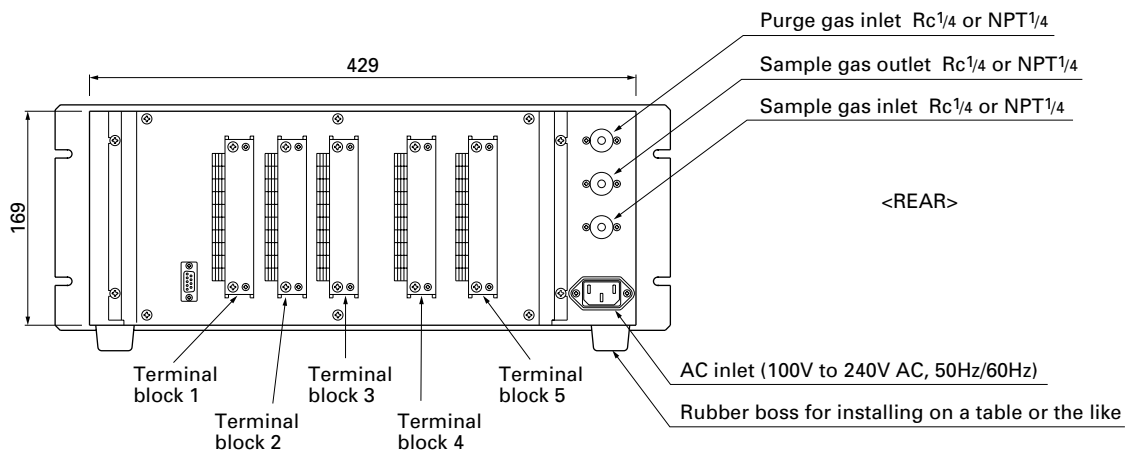

<REAR>

OUTLINE DIAGRAM OF ACCESSORY SLIDE RAIL (Unit: mm)

* The slide rails are attached to this equipment when designated.

Model : 305A-20/Accuride International Inc. or equivalent

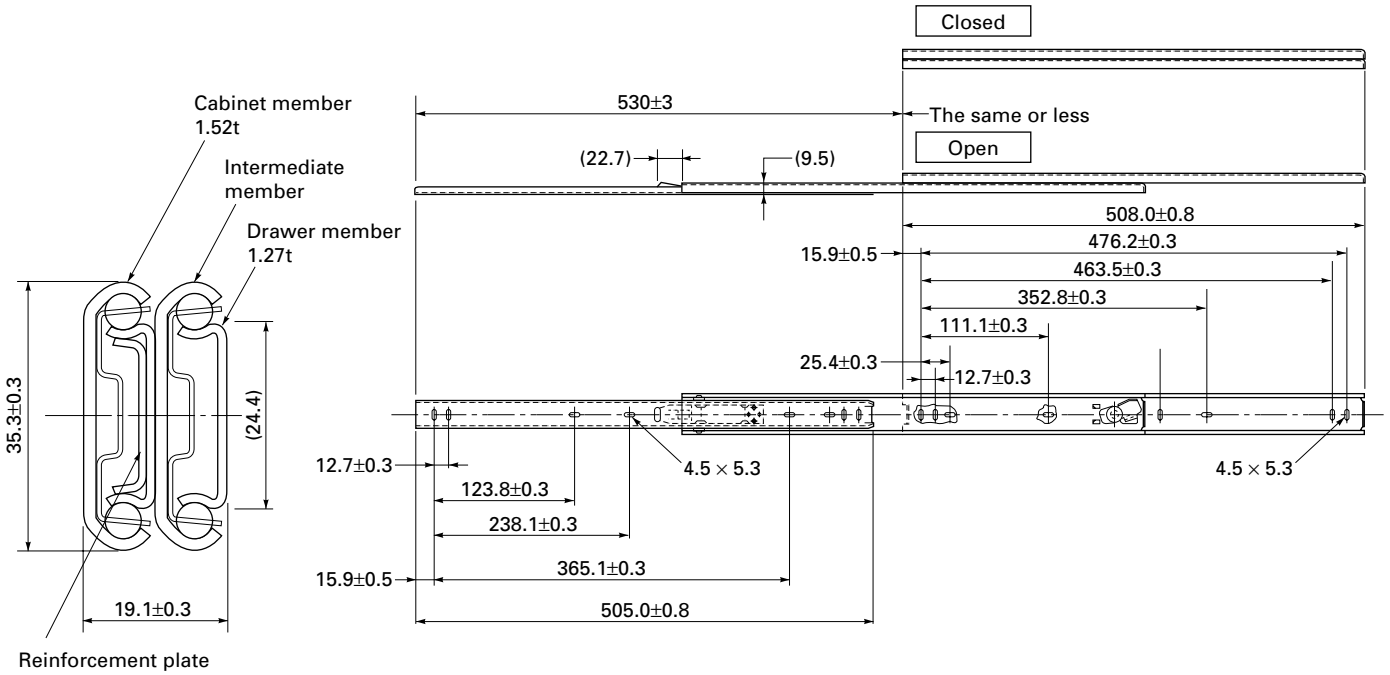

19-inch rack mounting method:

The mass of the instrument should be supported at the bottom of the unit (or the side of the unit when mounted with the slide rails).

Also, for facilitate maintenance, a structure which allows extraction of the main unit by using the slide rail is recommended.

Slide rail mounted type

Guide rail mounted type

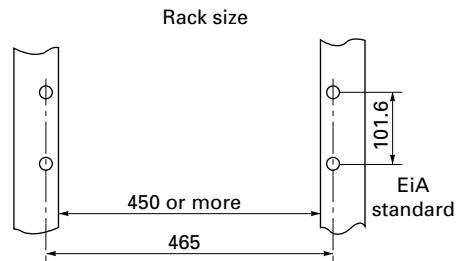
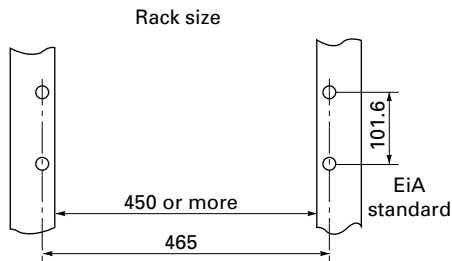

Mounting diagram

Mounting diagram

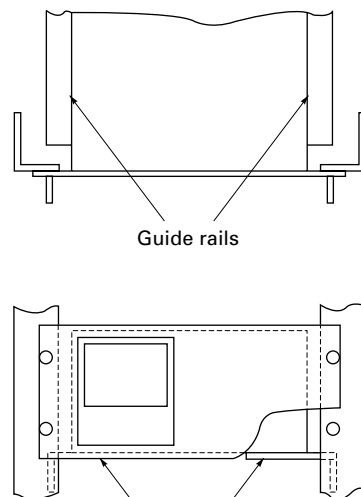
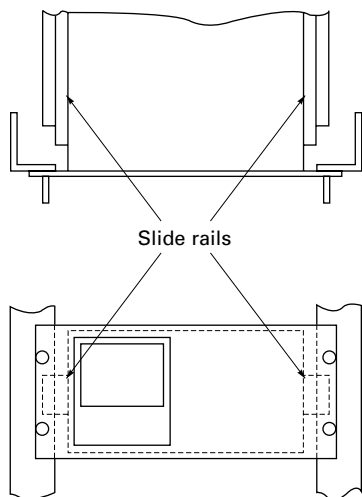

Guide rails
For the guide rail mounted type, a maintenance space (200mm or more) should be provided on the main unit.

EXTERNAL CONNECTION DIAGRAM

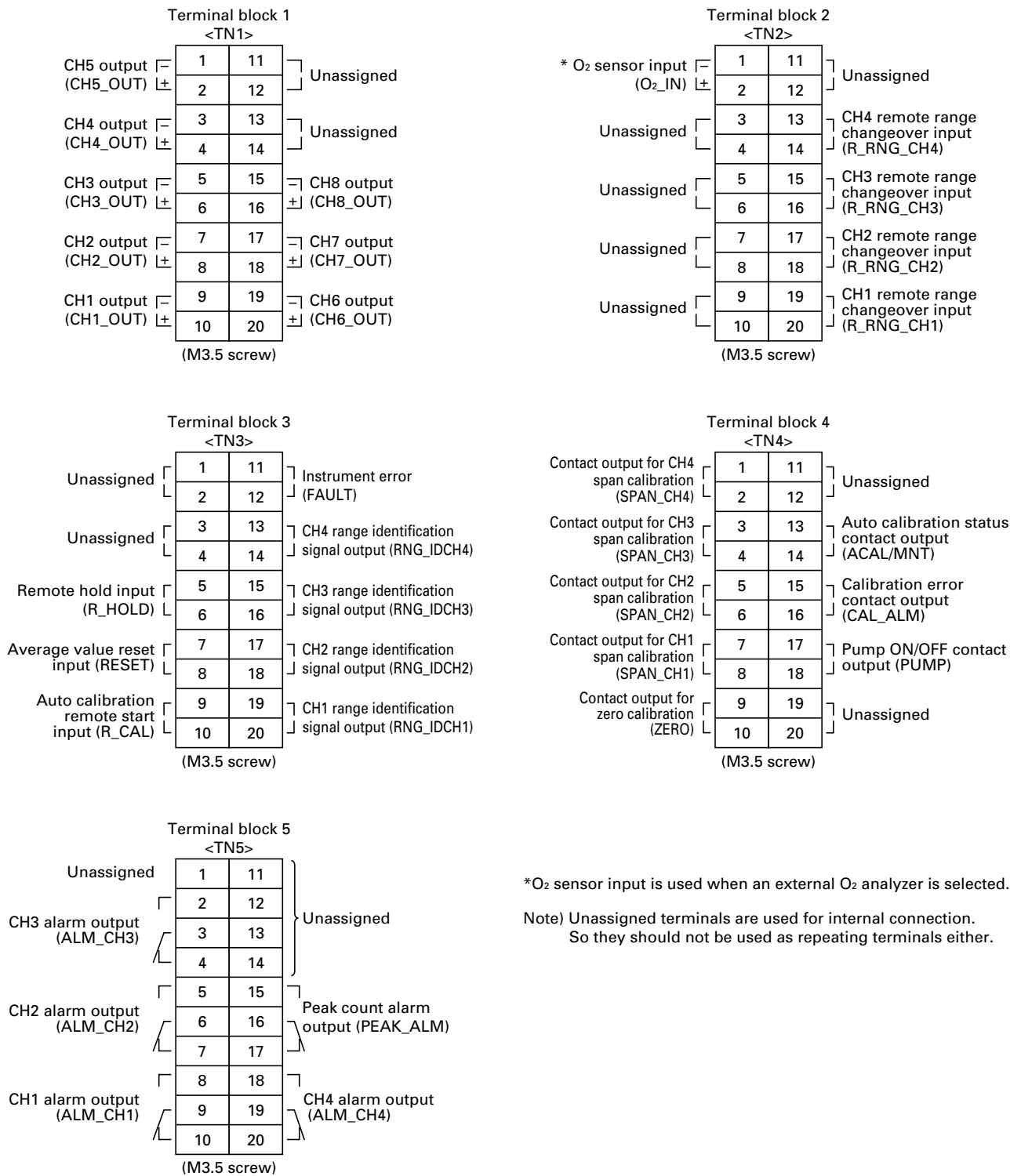

Exclusive Zirconia O₂ Sensor (to be purchased separately)

For O₂ correction, the gas analyzer ZKJ can accept linealized 0 to 1V DC signal coming from analyzer calibrated 0 to 25% O₂ full scale. If the analyzer is not available, Fuji can supply exclusive Zirconia O₂ sensor Model ZFK.

Measuring method:

Zirconia system

Measurable component and measuring range:

Measurable component		Range
O ₂	Oxygen	0 to 25vol%

- Repeatability:** Within ± 0.5% of full scale
- Linearity:** Within ± 1% of full scale
- Zero drift:** Within ± 1% of full scale/week
- Span drift:** Within ± 2% of full scale/week
- Response time:** Approx. 20 seconds (for 90% response)
- Measured gas flow rate:** 0.5 ± 0.25L / min

Remark: The Zirconia system, due to its principle, may produce a measuring error due to relative concentration versus the combustible O₂ gas concentration. Also, a corrosive gas (SO₂ of 250 ppm or more, etc.) may affect the life of the sensor.

Gas inlet/outlet size:

Rc1/4 or NPT1/4

Power supply:

Rated voltage ; 100 to 115V AC or 200 to 240V AC
 Rated frequency ; 50Hz/60Hz
 Max. rated power ; 215VA (during power ON)
 65VA (during steady-state operation)

Enclosure:

Steel casing, for indoor application

Indication:

Temperature indication (LED)

Temperature alarm output:

Contact output 1a contact,
 Contact capacity 220V, 1A AC (resistive load)

Outer dimensions (H x W x D):

140 x 170 x 190mm

Mass {weight}:

Approx. 3kg

Finish color:

Munsell 5Y 7/1

CODE SYMBOLS

1 2 3 4 5 6 7 8		9 10 11 12 13		Description									
Z	F	K	7	Y	Y	4	-	Y	0	Y	Y		
7 Y Y								Measuring method Zirconia method					
								Power supply					
1								100 to 115V AC 50/60Hz(Standard)					
2								100 to 115V AC 50/60Hz(With pot outlet)*					
3								200 to 240V AC 50/60Hz(Standard)					
4								200 to 240V AC 50/60Hz(With pot outlet)*					
7								200 to 240V AC 50/60Hz(CE mark)					
8								200 to 240V AC 50/60Hz (CE mark, with pot outlet)*					
								Gas inlet					
1								Rc 1/4					
8								NPT 1/4					

*: Select when SO₂ of 250ppm or more is included in measuring gases.

EXTERNAL CONNECTION DIAGRAM

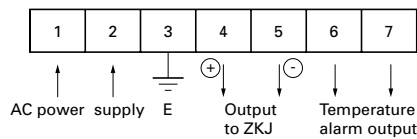

OUTLINE DIAGRAM (Unit:mm)

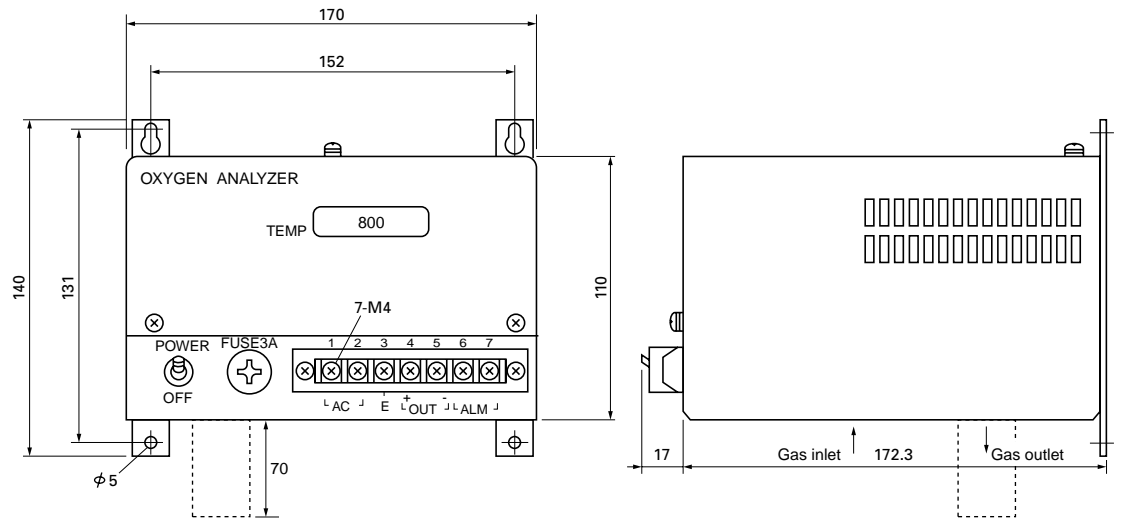

⚠ Caution on Safety

*Before using this product, be sure to read its instruction manual in advance.

Fuji Electric Systems Co.,Ltd.

Head Office

Gate City Ohsaki, East Tower, 11-2, Osaki 1-chome,
 Shinagawa-ku, Tokyo 141-0032, Japan
<http://www.fesys.co.jp/eng>

Instrumentation Div.

International Sales Dept.

No.1, Fuji-machi, Hino-city, Tokyo, 191-8502 Japan
 Phone: 81-42-585-6201, 6202 Fax: 81-42-585-6187
<http://www.fic-net.jp/eng>